

ITEM	DESCRIPTION	PART NO.	Mfr. CAGE	QTY.	REVISION HISTORY				
					ZONE	REV	E.C.O.	DESCRIPTION	BY/DATE
1	REAR SUPPORT DRAWER	SEE TABLE		2					
2	DWR, 3U, W/LOCK	SEE TABLE		1					
3	SCR, FNH, PHL, SST, W/WSHR	10-32 X .75		8					
4	WASHER, FLAT, SST	#10	N/A	4					
5	SCR, HEX HD,ZN	10-32X1/2		2					
6	NUT, HEX, SST	10-32 FLXLK		2					

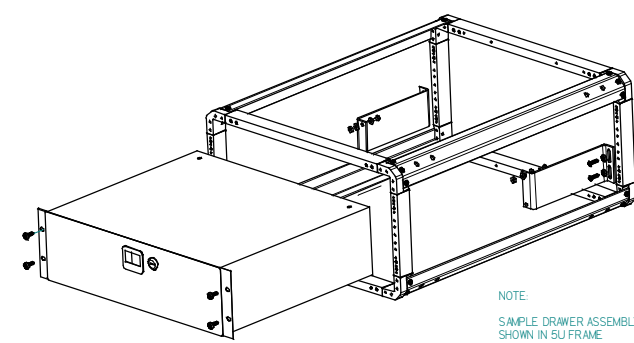
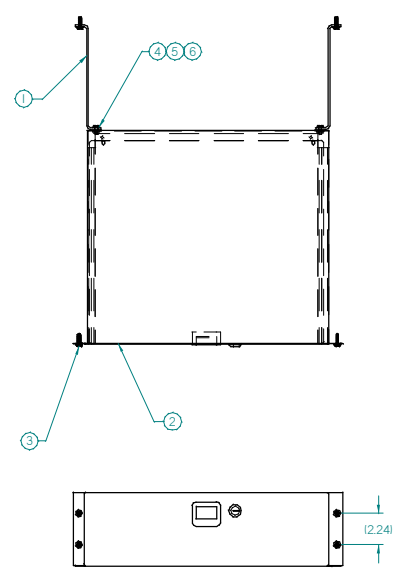

NOTE:
SAMPLE DRAWER ASSEMBLY SHOWN IN 5U FRAME. Iframe not included in kit

- INSTALLATION
1. ATTACH THE FRONT OF THE DRAWER (ITEM #2) TO THE FRAME AT THE FRONT OF THE CONTAINER (4X) USING ITEM #3 (4X)
 2. BOLT THE SUPPORTS (ITEM #1) TO THE FRAME AT THE BACK OF THE CONTAINER AT A HEIGHT THAT IS COMPATIBLE WITH THE HEIGHT OF THE DRAWER USING ITEM #3.
 3. USE BRACKET ITEM #1 AS A TEMPLATE TO DRILL HOLES IN BACK OF THE CONTAINER.
 4. BOLT THE SLOTTED HOLES IN THE SUPPORT TO THE HOLES DRILLED INTO THE DRAWER USING ITEMS #4, #5, #6.

2I-DRAWER-2-17	P73-103-2U-17		P66-393-17	17"
2I-DRAWER-2-18	P73-103-2U-18		P66-393-18	18"
2I-DRAWER-2-20	P73-103-2U-20		P66-393-20	20"
2I-DRAWER-2-23	P73-103-2U-23	DWR W/LK, 2U ATLANTIC D2LK	P66-393-23	23"
2I-DRAWER-2-25	P73-103-2U-25		P66-393-25	25"
2I-DRAWER-2-28	P73-103-2U-28		P66-393-28	28"
FRONTIER #	ASSY NO.	ITEM 2 DRAWER	ITEM #1 SUPPORT	FRAME LENGTH

2I-DRAWER-3-17	P73-103-3U-17		P66-393-17	17"
2I-DRAWER-3-18	P73-103-3U-18		P66-393-18	18"
2I-DRAWER-3-20	P73-103-3U-20		P66-393-20	20"
2I-DRAWER-3-23	P73-103-3U-23	DWR W/LK, 3U ATLANTIC D2LK	P66-393-23	23"
2I-DRAWER-3-25	P73-103-3U-25		P66-393-25	25"
2I-DRAWER-3-28	P73-103-3U-28		P66-393-28	28"
FRONTIER #	ASSY NO.	ITEM 2 DRAWER	ITEM #1 SUPPORT	FRAME LENGTH

2I-DRAWER-4-17	P73-103-4U-17		P66-393-17	17"
2I-DRAWER-4-18	P73-103-4U-18		P66-393-18	18"
2I-DRAWER-4-20	P73-103-4U-20		P66-393-20	20"
2I-DRAWER-4-23	P73-103-4U-23	DWR W/LK, 4U ATLANTIC D2LK	P66-393-23	23"
2I-DRAWER-4-25	P73-103-4U-25		P66-393-25	25"
2I-DRAWER-4-28	P73-103-4U-28		P66-393-28	28"
FRONTIER #	ASSY NO.	ITEM 2 DRAWER	ITEM #1 SUPPORT	FRAME LENGTH

REF:
UNIT:
CONTRACT NO.

COMPUTER CONTROLLED DOCUMENT
MANUAL CHANGES NOT ALLOWED

NEXT ASSY:	SCALE: 1/4"
TOLERANCE: UNLESS OTHERWISE SPECIFIED:	± .000
DR: J. KEYWORTH	DATE: 01-03-20
ENGR: C. LABRIE	DATE: 01-03-19
CHKD:	DATE:
TITLE: DWR TO FRAME ASSY, 3U W/LOCK DWG NO: P73-103 CASE CODE: 11214 SHEET: P101 OF 1	

This drawing and all copies are the sole property of HARDIGG INDUSTRIES, INC. No part of this drawing may be reproduced or transmitted in any form or by any means, electronic or mechanical, including photocopying, recording, or by any information storage and retrieval system, without the prior written permission of HARDIGG INDUSTRIES, INC. If you have any questions regarding this drawing, please contact your account manager or call 1-800-544-5395.