

8 7 6 5 4 3 2 1

- NOTES:
 1. 22 X 12 BLACK NYLON POUCH W/ZIPPER, LOCATED IN LID OF CASE.
 2. POUCH IS BOLTED ONTO INSIDE OF LID USING (2) SCREW/WASHER ASSY W/NUTS & WASHERS.
 3. POUCH FASTENED TO KNIFE EDGE USING (4) SCR/PH/PL.ZN/ST.

ITEM	DESCRIPTION	PART NO.	Mfr. CAGE	QTY.	REVISION HISTORY					
					ZONE	REV	E.C.O.	DESCRIPTION	BY/DATE	APPROVED/DATE
1	NYLON POUCH	P101-51		1						
2	SCREW/WASHER ASSY	P101-061		2						
3	WSHR, FL, SST, 1/4	9/32 X 11/16		2						
4	NUT, HEX, SST, FLXLK	1/4-20		3						
5	SCR/PH/PL.ZN/ST	10-16X.63		4						

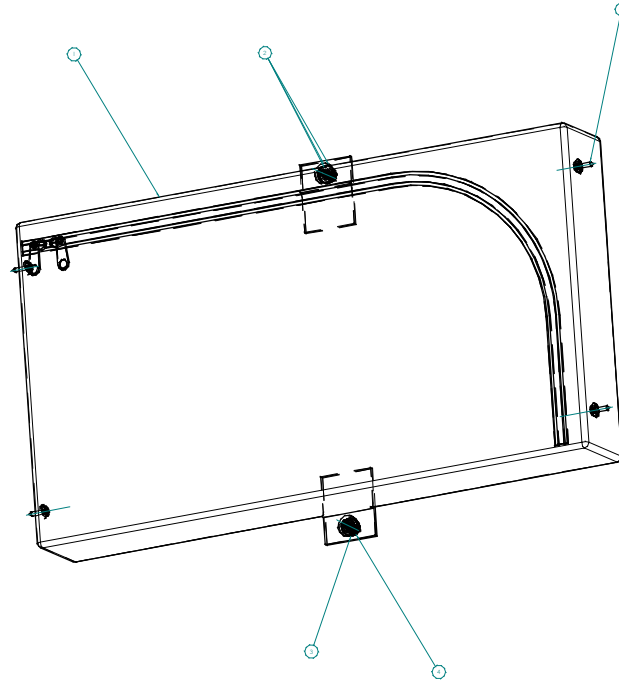

REF:
 UNIT:
 CONTRACT NO.

COMPUTER CONTROLLED DOCUMENT
 MANUAL CHANGES NOT ALLOWED

NEXT ASSY:		SCALE: 1/2	
TOLERANCE UNLESS OTHERWISE SPECIFIED:	± .000	± .000	± .000
DR: J KEYWORTH	DATE: 00-11-22	ENGR: Keyworth	DATE: 00-11-22
CHKD:	DATE:	APPRD:	DATE:
<small>This drawing and all copies and the data herein shall show to whom it is the property of HARDIGG INDUSTRIES, INC. So. Deerfield, MA, U.S.A. and include all proprietary information. The borrower, by accepting or using it, shall not be held liable for any loss or damage to any copy of the drawing or data and shall not be held liable for any loss or damage to any copy of the drawing or data by any other person or company. All copies of this drawing shall be made on the original drawing and shall be made on the original drawing.</small>		TITLE: POUCH OPTION RD2229 CNTNR	
SIZE: D	CAGE CODE: 11214	DWG NO: P073-0087	REV: 1
PROJ. NO: P073	SHEET 1 OF 1		

D

C

B

A

D

C

B

A

DWG NO: P073
 SHEET 1 OF 1